

Salco Lighting & Electrical Inc – Product Information Sheet

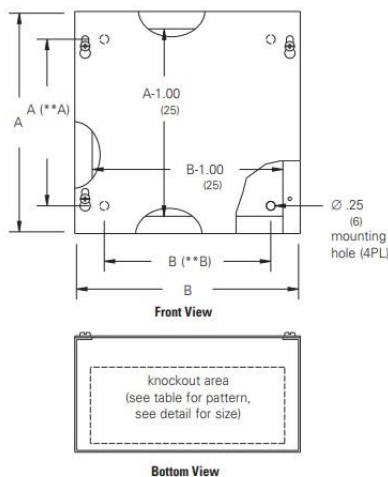

Junction Box Type 1
Model # SAL161166SC-JBT1



SPECIFICATIONS:

- Used as wiring boxes, junction and pull boxes
- Protects against contact with enclosed box
- UL 50 listed, Type 1
- CSA C22.2 No. 40 certified, Type 1
- Conforms to NEMA standard for Type 1
- Enclosure and cover are fabricated from code gauge steel or galvanized steel, (see table)
- Enclosure body has mounting holes on the back
- Enclosures are available with or without knockouts on the sides, top and bottom ends
- Cover is secured to the body with plated hex head combo screws
- Keyhole slots provided in the cover allow easy access to the inside without removing the screws
- Hole provision for optional ground lug kit